

GR Series

MODEL GRE24

BARRIER FREE, WALL MOUNTED, ANGLED,
BI-LEVEL DRINKING FOUNTAIN

STANDARD FEATURES

- Both Child or Adult ADA Compliant (when properly installed)
- Optionally Available with "Hands Free" Controls
- 18 Gauge, 304 Stainless Steel Bowls
- 12 Gauge, Heavy Duty Stainless Steel Arm, Corrosion and Scratch Resistant Finish
- Heavy Duty Stainless Steel, Vandal Resistant Bottom Access Panels
- 1/4" Thick Stainless Steel Mounting Plate
- Pushbutton With Cartridge Valve Assembly
- Polished Stainless Steel, Anti-Rotation, Non-Squirt Bubbler
- Resistant to Sunlight, Heat, Moisture and Wear
- 100-Mesh Inlet Strainer

SUGGESTED SPECIFICATIONS

Wall Mounted Round Bi-Level Drinking Fountain shall be Murdock model GRE24. Drinking Fountain shall be 18 gauge, type 304 stainless steel bowls with a 12 gage, heavy duty stainless steel support arm. Provide 1/4" thick stainless steel mounting plate to securely anchor unit to wall. Access Panels shall be secured with vandal-resistant stainless steel screws. Unit shall be activated by a front mounted, self-closing Pushbutton with Cartridge Valve Assembly, using less than 5 pounds of force to activate with an adjustable stream regulator controlling the water flow. Bubbler shall be polished stainless steel with a Non-Squirt feature and operate on water pressure range of 20-105 PSIG. P-Trap shall be installer provided behind wall (Optional -PT P-Trap with access below fixture is available). Fountain to be compliant to ANSI A117.1, Public Law 111-380 (NO-LEAD), CHSC 116875 and NSF/ANSI 61, Section 9. Fixture to meet ADA, ADA Standing Person, and ADA Child requirements when mounted appropriately.

Option Notes:

¹See separate option sheet

Complies with the following standards:



NSF/ANSI 61



Federal Public Law 111-380 (No Lead)



Model: GRE27-R Shown

"FOR INDOOR AND OUTDOOR USE"

MODEL:

(Must Specify)

- GRE24 Satin Stainless Finish
- GRE25 Green Powder-Coated
- GRE26 Red Powder-Coated
- GRE27 Blue Powder-Coated (Shown)

Custom color finishes available upon request

ADA DRINKING FOUNTAIN ORIENTATION

(Must Specify)

- L ADA Drinking Fountain Left Side (Opposite)
- R ADA Drinking Fountain Right Side (Shown)

OPTIONS

(additional costs may be incurred)

- FRA2 Freeze Resistant Valve, Two Valves¹
- LOGO Customer specified logo
- PT 1-1/4" OD P-Trap (Access Below Fixture)
- SOC Concealed Sensor Operation Drinking Fountains - Battery Operated Standard (N/A with -FRA2¹)
- 316 Type 316 Stainless Steel Construction



Member of U.S. Green Building Council



Recyclable Product



Water Conserving Product

⚠ WARNING: Cancer and Reproductive Harm - www.P65Warnings.ca.gov

* Valve specifications:
Minimum/Maximum
Pressure 30 to 100 psi.

GR Series
MODEL GRE24
WALL MOUNTED
DRINKING FOUNTAIN

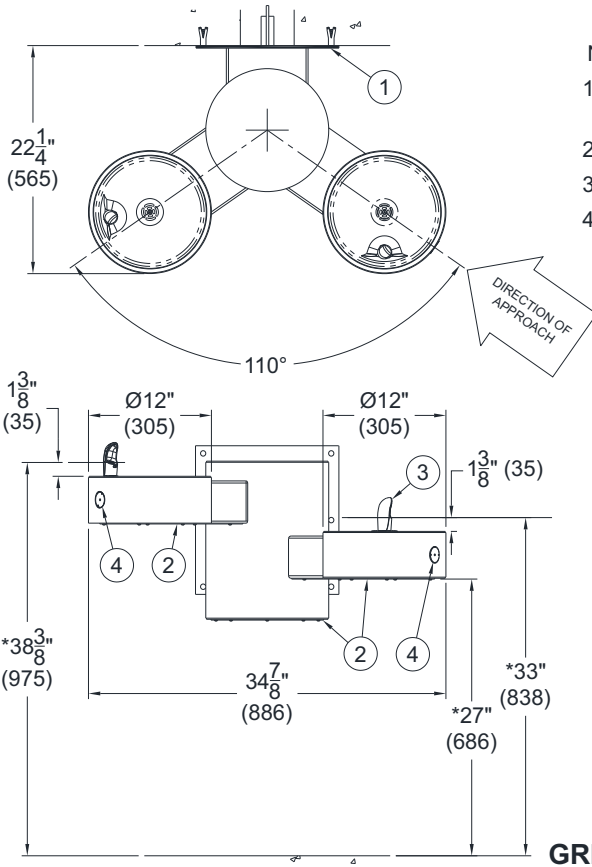

NOTES:

- 1/4" THICK STAINLESS STEEL STEEL MOUNTING PLATE
- REMOVABLE ACCESS PANELS
- DRINKING BUBBLER
- PUSHBUTTON CARTRIDGE VALVE ASSEMBLY
- SHOWN WITH OPTIONAL -PT 1-1/4" OD P-TRAP ASSEMBLY
- SUPPLY CONNECTION
- INSTALLER PROVIDED WALL ANCHORS AND ANCHORING HARDWARE

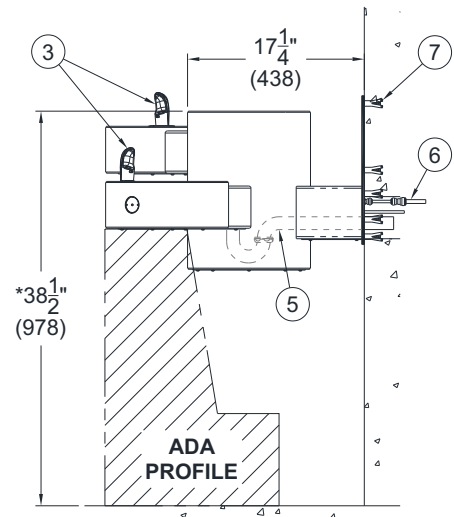

GRE24-R SHOWN

GENERAL NOTES:

- ALL DIMENSIONS ARE IN INCHES
- DIMENSIONS SHOWN ARE FOR RECOMMENDED ADULT HEIGHT. ADJUST VERTICAL DIMENSIONS AS NECESSARY TO COMPLY WITH FEDERAL, STATE AND LOCAL CODES.
- STOP VALVE NOT PROVIDED.

IMPORTANT: Refer to installation instructions for complete rough-in and technical data.
NOTE: Some options may change standard roughs.

Murdock Mfg.™ warrants that its products are free from defects in material or workmanship under normal use and service for a period of one year from date of shipment. Murdock's liability under this warranty shall be discharged solely by replacement or repair of defective material, provided Murdock™ is notified in writing within one year from date of shipment, F.O.B. Industry, California.

SELECTION SUMMARY & APPROVAL FOR MANUFACTURING	Model Number & Options _____	Quantity _____	All dimensions are subject to manufactures tolerance of plus or minus 1/2" nominal and subject to change without notice. Murdock assumes no responsibility for use of void or superseded data. Dimensions may change with the addition of optional accessories. Murdock Mfg.™, Member of Morris Group International™. Please visit www.murdockmfg.com for most current specifications.
	Company _____		
	Contact _____	Title _____	
	Signature (Approval for Manufacturing) _____	Date _____	